

4

3

2

1

NOTES:

- 1. APPLICABLE STANDARDS/SPECIFICATIONS:
ASME Y14.5M-1994, DIMENSIONING AND TOLERANCING
ASME Y14.38-1999, ABBREVIATIONS
- 2. COMPONENT OR ITEM TO BE COMPLIANT WITH THE MOST CURRENT REVISION OF THE RoHS / Wee DIRECTIVE FOR THE REDUCTION OF HAZARDOUS SUBSTANCES AND MATERIALS.
- 3. ALL DIMENSIONS ARE FOR REFERENCE ONLY.
- 4. TABLE PRINT: USE CHART ASSOCIATED WITH AIRMAN ASSEMBLY PART NUMBER. SUFFIXES (EXAMPLES -CLR AND -BLK) ATTACHED TO THE END OF THE AIRMAN PART NUMBER WILL INDICATE THE ANODIZATION COLOR (IF APPLICABLE)
- 5. ITEM INDIVIDUALLY SEALED IN BAG

| REV | DATE | EC # | ZONE | DESCRIPTION | DRAWN | CKD |
|-----|------------|------|------|-------------|-------|-----|
| A | 2020-08-02 | | | ORIGINATED | NR | JMA |

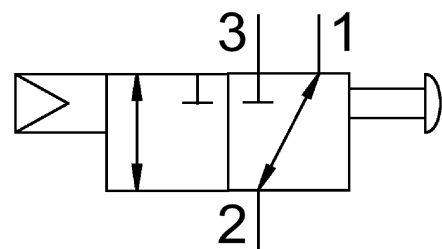
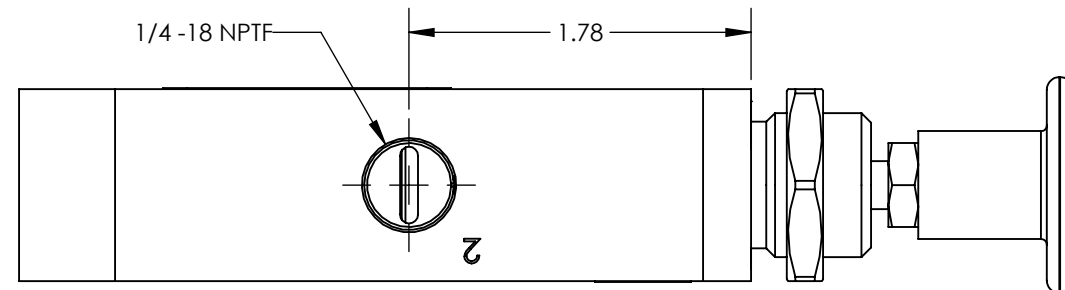
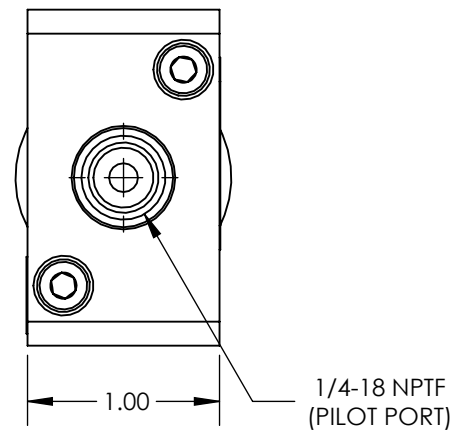
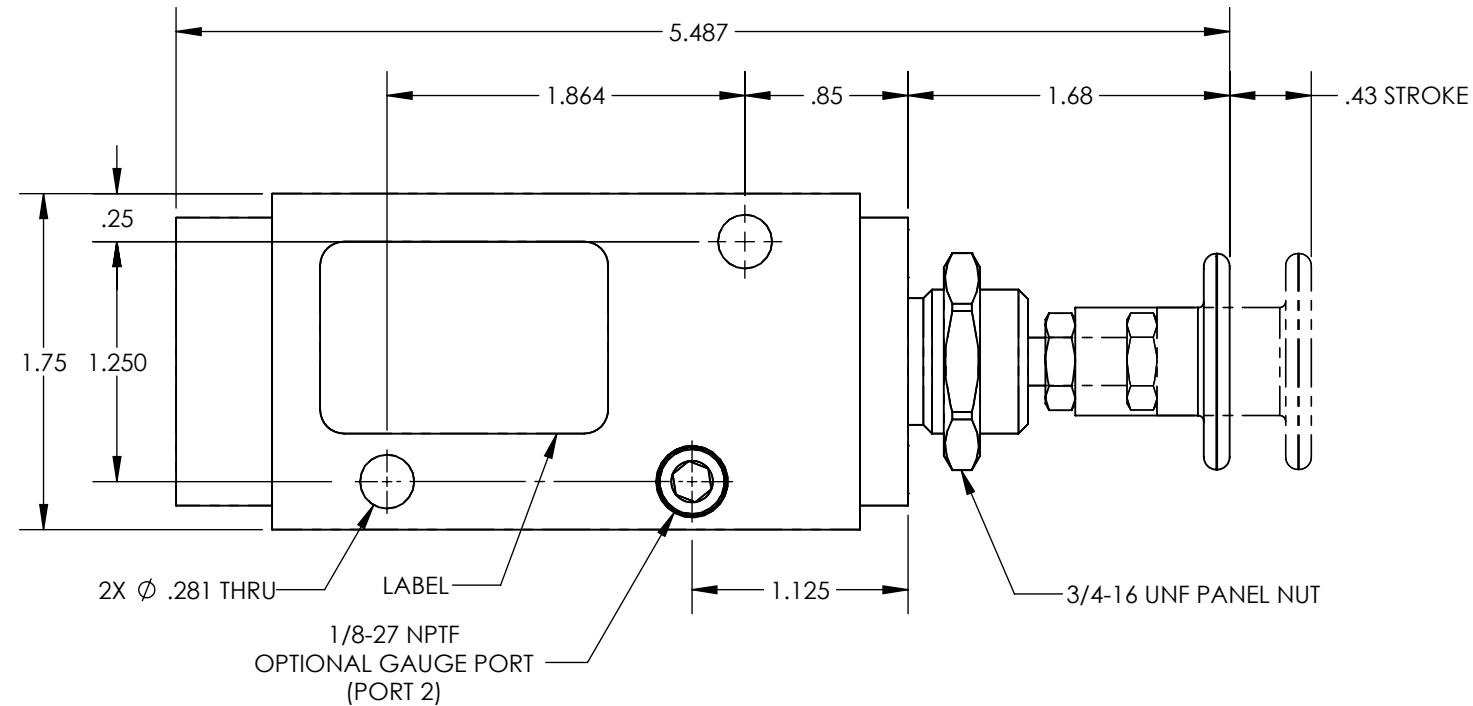
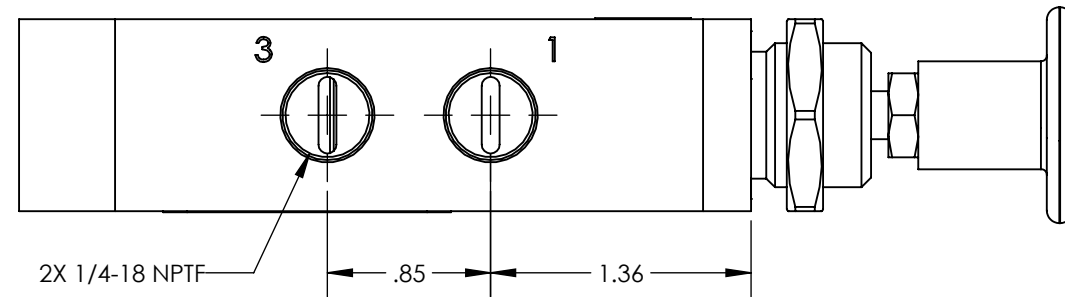

| | |
|--------------------------|-----------------------------------------------|
| FUNCTION | 3/2 PUSH/PULL WITH RESET AND GAUGE PORT |
| MECHANICAL MATERIALS | ALUMINUM BODY & END CAP |
| SEALS | LOW TEMP. NITRILE, LOW COMP. SET POLYURETHANE |
| FASTENERS | STAINLESS STEEL |
| MTG STYLE | PANEL OR BODY SIDE |
| ASSY LUBRICATION | HEAVY TRANSPORT SILICONE |
| FLOW | 2.25 Cv |
| TEMP | -40 TO 180°F |
| FILTRATION | 40 MICRON |
| SYSTEM LUBRICATION REQ'D | N/A |
| PRESSURE RANGE | MIN: 0 psi MAX: 150 psi PILOT: MIN. 55 psi |
| LEAK | N/A |
| ELECTRICAL VOLTAGE | N/A |
| CURRENT | N/A |

CUSTOMER PRINT

| AIRman PART NUMBER CHART | |
|--------------------------|-------------------|
| AIRman PART NUMBER | ANODIZATION COLOR |
| V254010421-K12 | NON-ANODIZED |
| V254010421-K12-BLK | BLACK-ANODIZED |
| V254010421-K12-CLR | CLEAR-ANODIZED |

NOTE: PART MUST BE CLEAN AND BURR FREE
MFG TOLERANCES UNLESS OTHERWISE NOTED:
ALL UNITS ARE INCHES
(2) DECIMAL PLACES: ±.01
(3) DECIMAL PLACES: ±.005
ANGLES: ±.5°
BREAK ALL EDGES .005/.015 X 45°
MACHINED SURFACES TO BE 63 RMS
CRITICAL CHARACTERISTIC - CONTROL PLAN REQUIRED

CONFIDENTIAL: THIS DRAWING OR ANY PART THEREOF IS PROPRIETARY AND MAY NOT BE REPRODUCED OR COPIED WITHOUT WRITTEN CONSENT OF AIRMAN PRODUCTS

| DRAWN BY | NR | DESCRIPTION |
|--------------|------------|----------------------------|
| NR | 2020-08-02 | VALVE, .25 NPT, 3-2, PP-AP |
| DRAWN DATE | B | PART NUMBER |
| DRAWING SIZE | SEE NOTES | V254010421-K12 |
| MATERIAL | 1:1 | |
| SCALE | 1 OF 1 | |
| SHEET # | | |

4

3

2

1